

Product Description

We designed the P19 and P20 diffusers with the contractor in mind. Each model provides damper and diffuser in one easy-to-install assembly. These products are versatile enough for 6, 7, or 8-inch flexible duct and offer throw patterns suitable for every application. And, our snap-in, Removable Core is designed for quick install and a finished look.



Features, Advantages, Benefits

- ❑ Rugged polymer construction provides long-lasting reliability.
- ❑ Molded, one-piece base and foam gasket means an air-tight fit and maximum performance.
- ❑ Adjustable collar fits 6, 7, or 8-inch duct and is removable.
- ❑ The low profile design produces high CFM.
- ❑ All mounting screws hide behind removable, snap-in core face, creating an attractive finish.
- ❑ Snap-in, snap-out core also makes for easy clean up.
- ❑ The built-in flex tie strap makes for a quick connection to flex duct.
- ❑ Reinforced, swivel locking clips facilitate a quick install and prevent costly stripping.

Models

P19—Square

Part #	Unit Size	External Size	Pattern
P19W 08082C	8"	11¼"	2-way
P19W 08083	8"	11¼"	3-way
P19W 08084	8"	11¼"	4-way

P20—Round

Part #	Unit Size	External Dia.	Pattern
P20W 08	8"	12 ¹ / ₈ "	360°

Accessories

Part #	Description
PCF	Ceiling Flange, galvanized
PPF	Plaster Frame, galvanized
PLIP	Ceiling Lay in Panel, white, 3 sizes

P19 Performance Data

Unit Size/Pattern	Collar Size/Ak	Face Velocity	300	400	500	600	700	800	900	1000
		Pressure Loss	.006	.010	.016	.022	.031	.040	.050	.062
8"/4-way	6"/.18"	CFM	54	72	90	108	126	144	162	180
		Throw	2	2.5	3	3.5	4	4.5	5	5.5
	7"/.25"	CFM	75	100	125	150	175	200	225	250
		Throw	3	4	5	6	7	8	9	10
	8"/.33"	CFM	99	132	165	198	231	265	297	330
		Throw	4	5	6	7	8	9	10	11
8"/3-way	6"/.18"	CFM	54	72	90	108	126	144	162	180
		Throw A/B	3/1.5	4/2	5/2.5	6/3.5	8/4.5	9/5	10/6	11/6.5
	7"/.25"	CFM	75	100	125	150	175	200	225	250
		Throw A/B	3.5/2	4.5/2.5	6/3	7/4	9/5	10/5.5	11/6.5	12/7
	8"/.30"	CFM	90	120	150	180	210	240	270	300
		Throw A/B	4/2.5	5/3	7/4	8/4.5	10/5.5	11/6	12/7	13/7.5
8"/2-way	6"/.18"	CFM	54	72	90	108	126	144	162	180
		Throw	2.5	3.5	4.5	5.5	6.5	7.5	8.5	9.5
	7"/.25"	CFM	75	100	125	150	175	200	225	250
		Throw	3	4	5	6	7	8	9	10
	8"/.28"	CFM	84	112	140	168	196	224	252	280
		Throw	4	5	7	8	9	10	11	12

Terminal Velocity = 50 fpm

☐ ≤ NC 20-30

■ NC 30-35

P20 Performance Data

Unit Size/ Hole Size	Face Velocity	300	400	500	600	700	800	900	1000
	Pressure Loss	.006	.010	.016	.022	.031	.040	.050	.062
8"/6" Ak=.18	CFM	54	72	90	108	126	144	162	180
	Throw	3	4	5	7	8	9	10	11
8"/7" Ak=.25	CFM	75	100	125	150	175	200	225	250
	Throw	4	5	6	8	9	11	12	13
8"/8" Ak=.26	CFM	78	104	130	156	182	208	234	260
	Throw	5	6	7	9	10	12	13	15

Terminal Velocity = 50 fpm

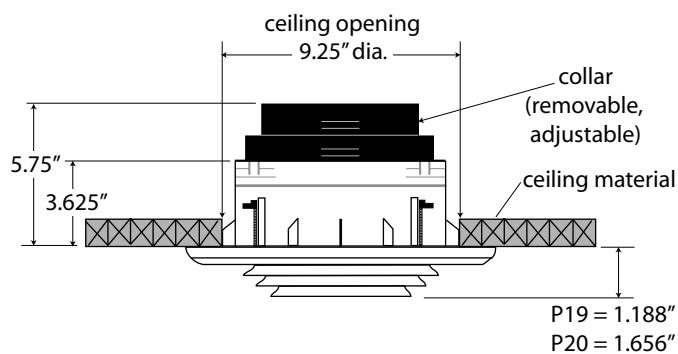

Continental Register
a division of Continental Industries, Inc.
100 West Windsor Avenue
Elkhart, Indiana 46514

Phone: 800.735.5272

Fax: 574.262.2075

Email: crc@theregisterpeople.com

Web: www.theregisterpeople.com